

HG Series Roller Graders

Piscis roller graders are design to separate large volumes of fish by the width of the product. The product travels down a set of rotating rollers that gradually increase in width between them. The size of the gap and the starting width are determined by the user. The graders are normally accompanied by an infeed hopper, a stand and grade take away conveyors.

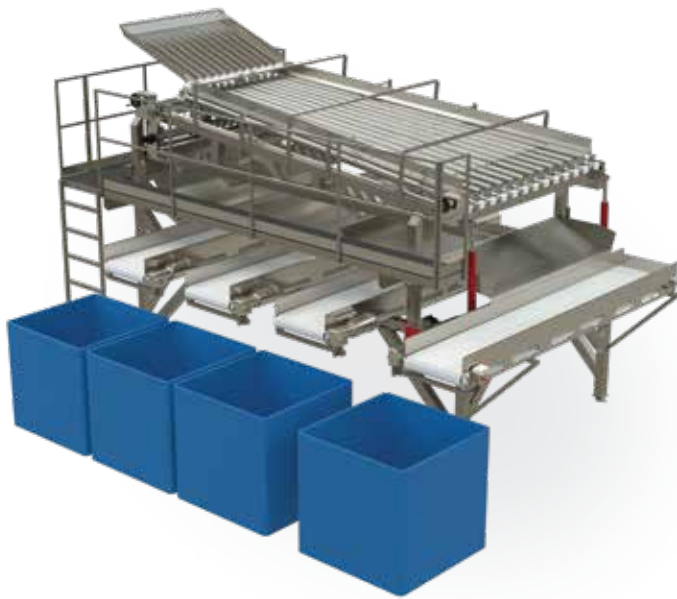

METHOD OF OPERATION

The fish travel between sets of 2 rotating rollers that gradually spread apart, guiding them downward gently. Water is sprayed on the rollers to ensure the fish are handles gently. After passing through rollers, fish are sorted into 4 grades at the machine's side, with 5th oversize grade over the end of machine. Both the starting and finishing roller widths are adjustable. The single point adjustment utilizes a scale indicator to position rollers accurately. Fish are evenly spread between rollers using a vibrating table to prevent "piggy backing", where small fish stack on larger ones. Hydraulic cylinders adjust the angle of decent and speed of fish down the rollers.

KEY FEATURES

- High-speed for production rates
- Open hygienic design
- Gentle fish handling
- Easy to operate and maintain
- Low operating and maintenance costs
- Robust design
- Small footprint
- Easy and fast adjustment for different fish size

**SPECIFICALLY DESIGNED
THE THROUGHPUT PER HOUR FOR THE
MACHINES IS 10 TO 30 TONS DEPENDING ON
THE NUMBER OF ROLLERS. STANDARD LENGTH
OF ROLLERS - 4 METERS STANDARD NUMBER
OF ROLLERS - 5 TO 13 ADDITIONAL ROLLERS
AND LENGTHS ARE AVAILABLE UPON REQUEST.**

WIDE RANGE OF SPECIES

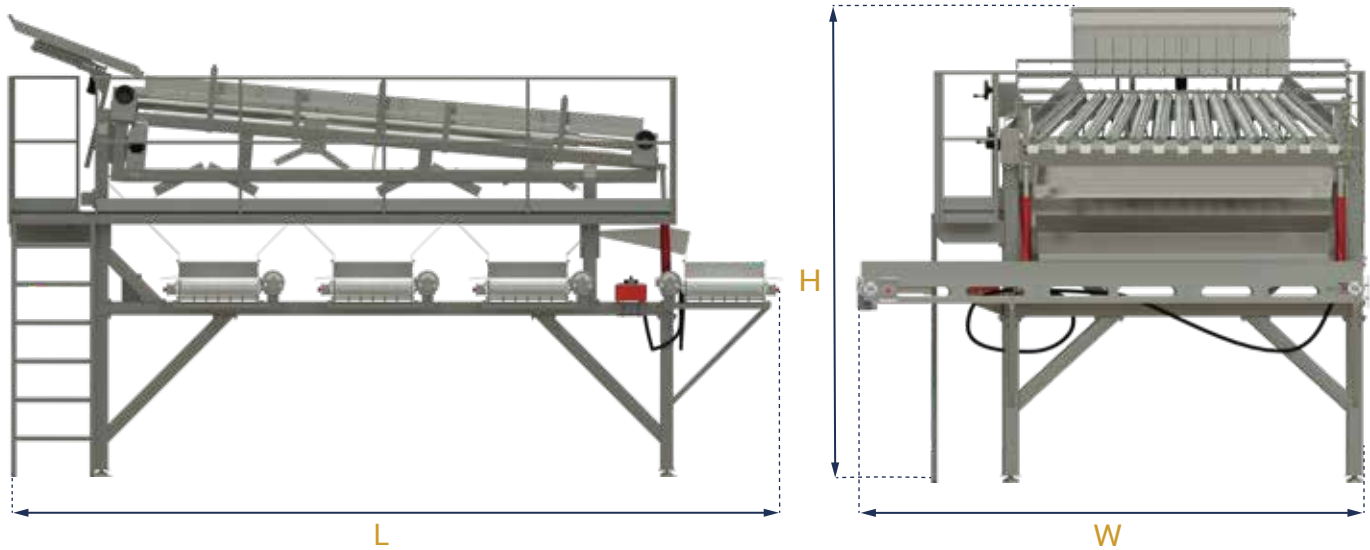

Detailed drawings are available on request.

Exclusively Devoted to the Fish Processing Industry

Utilities



Standard Garden Hose Connection $\frac{3}{4}$ female



Per customer specifications, single or three phase available

The HG Series machines are subject to U.S and International patents and meets all CE machine directives..

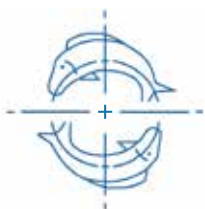

***PISCES FISH
MACHINERY, Inc.***

P.O. BOX 189

WELLS, MICHIGAN 49894, TEL: 906/789-1636

FAX: 906/789-1211

E-MAIL: piscis@piscis-ind.com

WEB: www.piscis-ind.com