

PISCES FISH MACHINERY, Inc.

FR-150 and FR-200 *Filleting Machines*



The Pisces FR-150 and FR-200 are reliable, versatile, high-speed filleting units specially designed for the production of single fillets free of backbone and ribs. Only minor adjustments are required to process a wide variety of fish species and sizes due to the machines' unique location method that utilizes the internal bone structure of the fish.

Method of Operation An operator places the head-off fish onto the feed system between the feed rollers which carry the fish into the drive belts. (Infeed systems for either eviscerated or non-eviscerated fish are available.)

The drive belts then transport the fish over the belly cutting blades and belly cleaning wheel and past the backbone removal blades.

The backbone and offal are ejected into the waste chute and the two separate halves of the fish are located onto rib guides for transportation past the rib removal blades. The ribs are then removed and ejected into the waste chute, and the two fillets are placed skin-down onto a discharge conveyor.

The FR-150 is specially designed to accommodate fish in the size range of 3 oz. to 16 oz., such as Lake Perch, Bass, Trout, Bream and Garfish.

The FR-200 is suitable for a variety of fish in the size range of 12 oz. to 4 lbs., including Trout, Ocean Perch, Lake Perch, Redfish, Whitefish, Walleye, Tilapia, Mullet, Salmon, Mackerel, Bass, Sea Bass and Sea Bream.



- **High speed**
- **One operator**
- **Versatile design**
- **Simple to operate**
- **Easy to maintain**
- **Low operating cost**

FR-150 and FR-200 Filleting Machines

Technical Specifications

Water Connections	Standard garden hose connection 1/2"	
Water Usage	3 US gallons per minute or 12 liters per minute	
Belt Speed	60 feet per minute	
Electrical	Per Customer Specifications	
Power	12.4 amps full load, @ 220 v, 3 Kw	
Operators	One	
Net Weight	FR 150 - 740 Lbs. (336 Kg)	FR 200 - 840 Lbs. (331Kg)
Weight Export Crated	FR 150 - 890 Lbs. (404Kg)	FR 200 - 990 Lbs. (450 Kg)
Crate Volume	42"Width x 75"Length x 48"Height (107cm x 191cm x 122cm)	

Specifications subject to change without notice • This machine is subject to U.S. and International patents and meets all CE machine directives.

W= Water connection • **E**= Electrical connection • **A**= Air connection

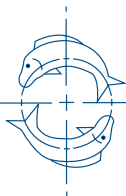
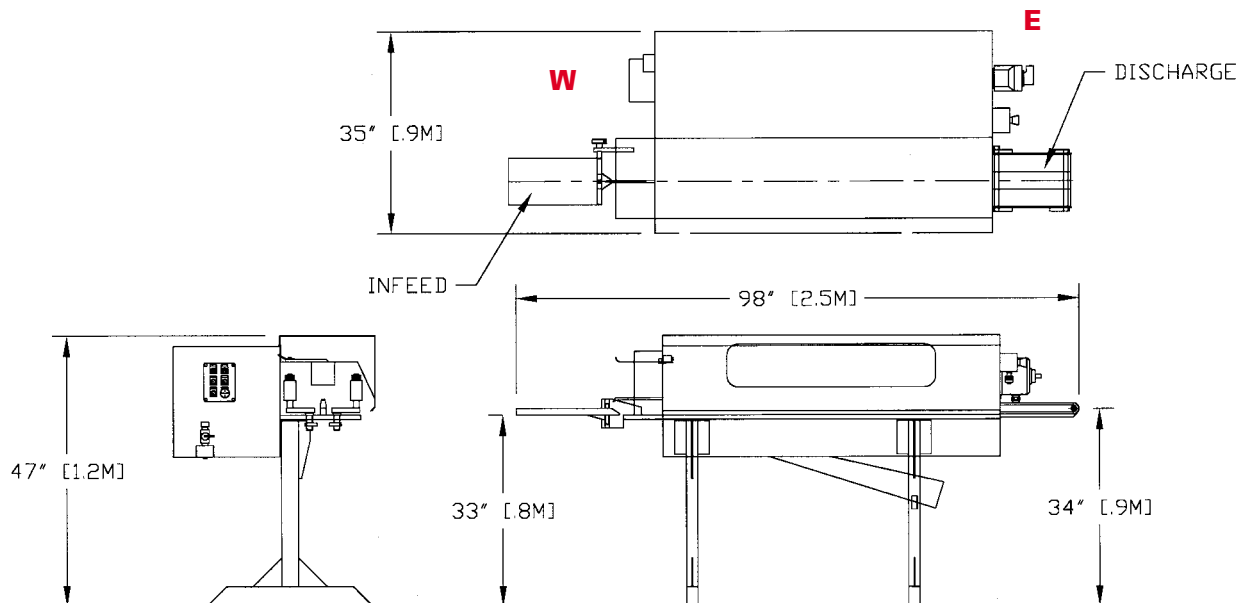

PISCES FISH MACHINERY, Inc.

P.O. BOX 189
WELLS, MICHIGAN 49894
TEL: 906/789-1636
FAX: 906/789-1211
E-MAIL: pisces@pisces-ind.com